

SCIENTIFIC DATA SYSTEMS

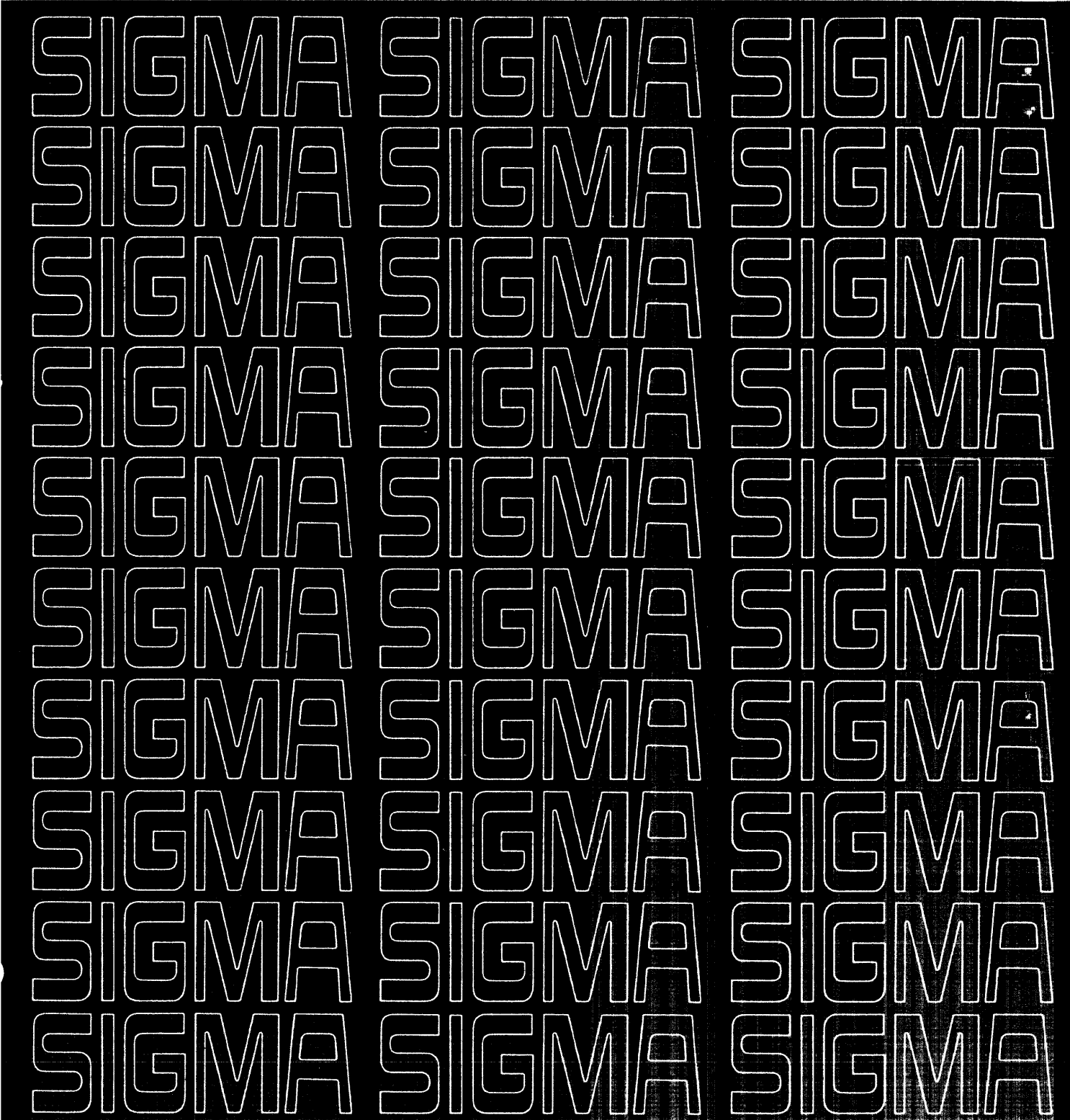

LINE PRINTER ORDER CODES

<u>Code</u> <u>(Hexadecimal)</u>	<u>Name</u>
01	Print a Line
03	Format
05	Print with Format
41	Print and Interrupt on Data Transmission Completed
43	Format and Interrupt on Data Transmission Completed
45	Print with Format and Interrupt on Data Transmission Completed

FORMAT CONTROL CODES

<u>Code</u> <u>(Hexadecimal)</u>	<u>Character</u>	<u>Function</u>
60, E0	-	Inhibit Automatic Space after Print
C1	A	Space 1 line
C2	B	Space 2 lines
C3	C	Space 3 lines
C4	D	Space 4 lines
C5	E	Space 5 lines
C6	F	Space 6 lines
C7	G	Space 7 lines
C8	H	Space 8 lines
C9	I	Space 9 lines
CA		Space 10 lines
CB		Space 11 lines
CC		Space 12 lines
CD		Space 13 lines
CE		Space 14 lines
CF		Space 15 lines
F0	0	Skip to Channel 0 (bottom of page)
F1	1	Skip to Channel 1 (top of page)
F2	2	Skip to Channel 2
F3	3	Skip to Channel 3
F4	4	Skip to Channel 4
F5	5	Skip to Channel 5
F6	6	Skip to Channel 6
F7	7	Skip to Channel 7

Price: \$.75

BUFFERED LINE PRINTERS

MODELS 7440/7445

REFERENCE MANUAL

for

SDS SIGMA COMPUTERS

90 10 14C

August 1968



SCIENTIFIC DATA SYSTEMS/701 South Aviation Blvd./ El Segundo, California 90245

REVISIONS

This publication, 90 10 14C, is a minor revision of the SDS Sigma Buffered Line Printers Reference Manual, 90 10 14B. A change in text from that in the previous manual is indicated by a vertical line in the margin of the affected page.

RELATED PUBLICATIONS

<u>Title</u>	<u>Publication No.</u>
SDS Sigma 2 Computer Reference Manual	90 09 64
SDS Sigma 5 Computer Reference Manual	90 09 59
SDS Sigma 7 Computer Reference Manual	90 09 50
SDS Sigma 5/7 Symbol and Meta-Symbol Reference Manual	90 09 52
SDS Sigma 2 Symbol Reference Manual	90 10 51

ALL SPECIFICATIONS SUBJECT TO CHANGE WITHOUT NOTICE

CONTENTS

1.	GENERAL DESCRIPTION	1
	SDS Model 7440/7445 Buffered Line Printers	1
2.	FUNCTIONAL DESCRIPTION	1
	Data Representation	1
	Printing	1
	Character Selection	1
	Line Printer States	2
	Operational States	2
	Transitions between States	3
	Data Transfer	3
3.	PROGRAM INTERFACE	4
	Print Orders	4
	Print Order Modifier	5
	Formatting	5
	Automatic Form Control	5
	Ordered Form Control	5
	Key Events	5
	Start Input/Output	5
	Unusual End Conditions	5
	Channel End Conditions	6
	Fault Conditions	6
	Error Conditions	6
	Line Printer Status Response	7
	I/O Instruction Status Bits	7
	Device Status Byte	8
	Operational Status Byte	9
	Programming Considerations	9
4.	OPERATIONS	11
	Operator Controls	11
	Power On	11
	Operational	11
	Top of Page	11
	Form Advance	11
	Start	11
	Stop	11
	Paper Low	11
	Fault/Reset	11
	Operating Procedures	12
	Paper Loading	12
	Ribbon Loading	13
	Turn-On/Turn-Off Procedures	14
	Phasing Control	14
	Vertical Print Line Adjustment	14
	Intensity Control Adjustment	14
	VFU Tape Loading	15

Vertical Format Tape Preparation		15
Vertical Format Tape Punch		15
SDS Standard Tapes		16
Preparing Standard Tapes		16

APPENDIXES

A.	DEVICE STATE SEQUENCES	17
B.	SIGMA 7 PROGRAM EXAMPLE	22

ILLUSTRATIONS

Model 7440/7445 Line Printer		iv
Line Printer Paper Guide		iv
1.	Controlling System/Line Printer Actions	10
2.	Control Panel	11
3.	Printer Mechanism, Front View	12
4.	Printer Mechanism, Rear View	13
5.	Ribbon Mounting	14
6.	Right Control Bay	15
7.	VFU Tape Punch	15
8.	Tape Alignment in VFU Tape Punch	16
9.	Device State Sequence from Not Operational	17
10.	Device State Sequence from Operational	17
11.	Device State Sequence from Ready-Manual	18
12.	Device State Sequence from Ready-Auto	19
13.	Device State Sequence from Busy-Manual	20
14.	Device State Sequence from Busy-Auto	21

TABLES

1.	Specifications	1
2.	Graphic Set for SDS 7440/7445 Line Printers	2
3.	Line Printer State Transitions	3
4.	Line Printer I/O Instruction Execution Response	7
5.	Paper Characteristics	13
6.	Ribbon Characteristics	14
7.	Specifications for Standard Control Tapes	16

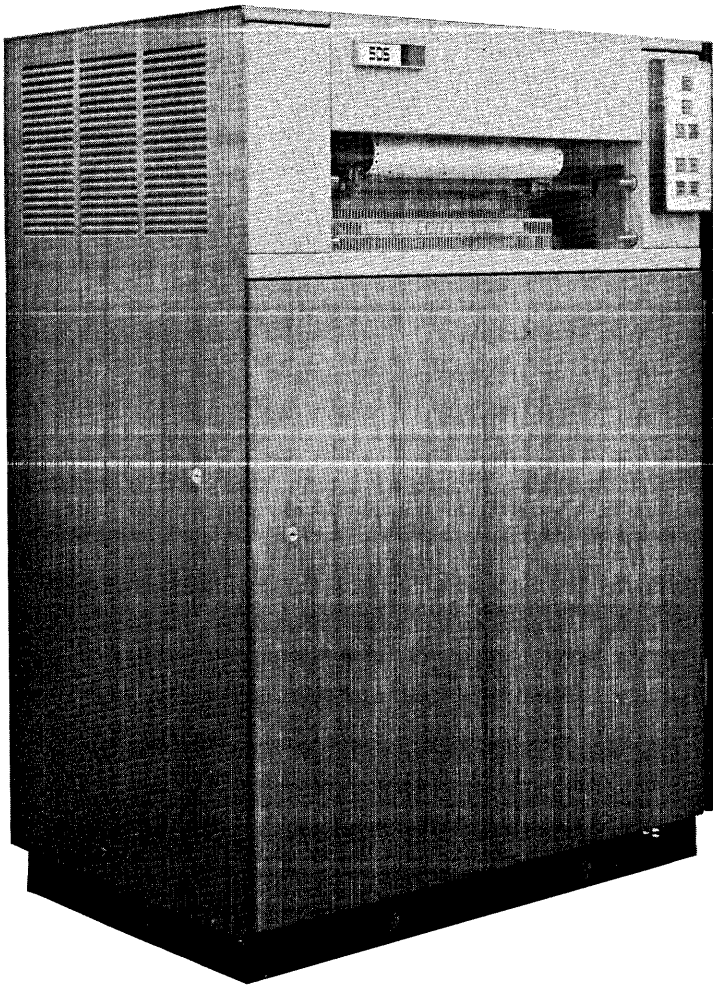

Model 7440/7445 Line Printer

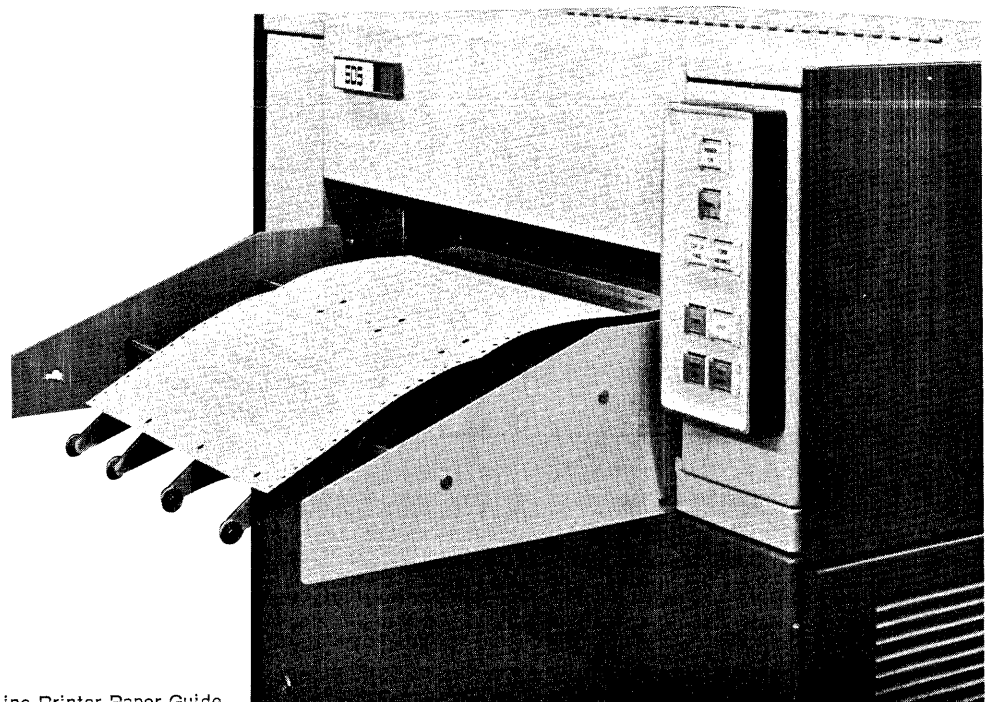

Line Printer Paper Guide

1. GENERAL DESCRIPTION

SDS MODEL 7440/7445 BUFFERED LINE PRINTERS

The SDS Model 7440 and 7445 Line Printer subsystems each consist of a line printer and controller assembly. The printer controller provides for a single line printer device and may be connected to only one I/O channel. Using a character set that consists of 56 graphics plus a blank, the printer is capable of printing 132 columns of information. Graphics are permanently embossed on a rotating print drum, and print hammers are provided for each of the 132 columns that constitute a printed line. To achieve maximum printing speed, characters are situated sequentially on the drum according to their frequency of use.

Buffering is provided as a built-in feature of both Models 7440 and 7445. Buffering prevents the line printer from tying up the computer's input/output system while a line of characters is being printed. The printer accepts a full line (132 characters) at one time. It then holds this line in its buffer (a small integrated-circuit memory) while the line is being printed.

Table 1. Specifications

Operating Characteristics	
Printing Speed	
Model 7440	628 lines/min (minimum) 800 lines/min (maximum)
Model 7445	760 lines/min (minimum) 1000 lines/min (maximum)
Number of columns	132

Table 1. Specifications (cont.)

Operating Characteristics	
Printable characters	56
Paper feed rates	18.5 ms/line 15 in./sec slew
Line spacing	6 lines/in.
Vertical format unit	8-channel paper tape
Forms	Standard edge punched, 4 in. to 20 in. wide
Physical Dimensions	
Height	52.5 in.
Width	38.5 in.
Depth	24.5 in.
Weight (approximate)	900 lb
Environmental Characteristics	
Power requirements	115 vac \pm 10%, 60 \pm 0.5 Hz, 2.0 kw
Operating temperature	50°F to 100°F
Operating humidity	20% to 80%

2. FUNCTIONAL DESCRIPTION

DATA REPRESENTATION

PRINTING

The buffered line printer is capable of storing up to 132 bytes of data (8 bits/byte) in an internal buffer and transcribing the coded data into one of 56 printable EBCDIC[†] characters for each byte. Character decoding is accomplished within the printer by a comparison process between each stored data byte and a coded character position disc rotating in unison with the print drum. As each byte is matched with its respective character code, the print hammer corresponding to the position of

the byte in the print line is energized and the corresponding character is imprinted on the copy. This process is repeated until each data byte has been transcribed; the maximum time is one complete drum revolution. That is, completion of printing occurs as soon as all characters have been printed, independent of the position of the print drum. An initial parity check is made on all data bytes received by the printer. Additional parity checking is done each time data is removed from the print buffer for decoding.

CHARACTER SELECTION

The line printer graphic character set (Table 2) consists of 56 SDS standard alphabetic, numeric, and special characters, plus blanks. Each 8-bit byte represents one character code to the printer. However, only the six least-significant bits are used in character decoding. The remaining two most

[†] A table showing the Extended Binary-Coded-Decimal Interchange Code (EBCDIC) is given in the SDS Sigma Computer Reference Manuals.

Table 2. Graphic Set for SDS 7440/7445 Line Printers

Character	6-Bit Code	Hex. Code	Character	6-Bit Code	Hex. Code	Character	6-Bit Code	Hex. Code
Blank	00 0000	40	I	00 1001	C9	<	00 1100	4C
0	11 0000	F0	J	01 0001	D1	(00 1101	4D
1	11 0001	F1	K	01 0010	D2	+	00 1110	4E
2	11 0010	F2	L	01 0011	D3		00 1111	4F
3	11 0011	F3	M	01 0100	D4	&	01 0000	50
4	11 0100	F4	N	01 0101	D5	\$	01 1011	5B
5	11 0101	F5	O	01 0110	D6	*	01 1100	5C
6	11 0110	F6	P	01 0111	D7)	01 1101	5D
7	11 0111	F7	Q	01 1000	D8	;	01 1110	5E
8	11 1000	F8	R	01 1001	D9	-	10 0000	60
9	11 1001	F9	S	10 0010	E2	/	10 0001	61
A	00 0001	C1	T	10 0011	E3	,	10 1011	6B
B	00 0010	C2	U	10 0100	E4	%	10 1100	6C
C	00 0011	C3	V	10 0101	E5	>	10 1110	6E
D	00 0100	C4	W	10 0110	E6	:	11 1010	7A
E	00 0101	C5	X	10 0111	E7	#	11 1011	7B
F	00 0110	C6	Y	10 1000	E8	@	11 1100	7C
G	00 0111	C7	Z	10 1001	E9	'	11 1101	7D
H	00 1000	C8	.	00 1011	4B	=	11 1110	7E

significant bits are used by the controller for parity checking only. For example, the EBCDIC codes

```

0001 0101 (15) New Line - NL
0101 0101 (55) undefined
1001 0101 (95) n
1101 0101 (D5) N
    
```

are all interpreted by the line printer as

01 0101

which represents the letter N. This means that all lower case alphabetic characters print as the corresponding upper case character.

Character codes not recognized by the printer are printed as blanks. Thus, the EBCDIC codes

```

0010 1101 (2D) undefined
0110 1101 (6D) undefined
1010 1101 (AD) -
1110 1101 (ED) undefined
    
```

are all interpreted by the line printer as

10 1101

which is an undefined character and is printed as a blank. (The EBCDIC code 40 is the standard code for blank.)

LINE PRINTER STATES

The initial state of the line printer is a function of its power status. The complete absence of power to the subsystem, that is, the absence of its prime ac power or system dc power effectively removes the line printer from the system. Thus, any attempt to access the printer results in a response

of "no address recognition" to an I/O instruction. The presence of system dc power in the absence of ac power enables address recognition but holds the subsystem in a "not operational" state. Failure of power supplies inside the printer also causes it to assume a "not operational" status.

OPERATIONAL STATES

The presence of all power to the subsystem enables the printer to assume any one of four operational states. An operational machine state is a combination of the machine condition and mode status.

The exact condition and mode status of the printer at any given time is returned to the CPU in response to I/O instructions, like SIO, HIO, and TIO. Other I/O instructions, such as AIO and TDV, provide more detailed indications of the printer's status - paper runaway, fault, etc. A brief explanation of the possible machine conditions and modes indicated by the printer follows.

CONDITIONS

Ready. In the "ready" condition the printer is capable of accepting an order from the controlling system to print or to move paper. Various interlocks are provided to insure that the printer is capable of operation before indicating this condition.

Busy. In the "busy" condition the printer is actively engaged in performing a print or paper movement operation ordered by the controlling system. The printer will not accept a new SIO instruction as long as this condition prevails.

MODES

Manual. The printer will automatically assume the "manual" mode when any condition arises requiring operator intervention before the printer can function normally (e.g., paper low, paper runaway, etc.). The "manual" mode is forced upon the printer when either the RESET or STOP switch at the printer control panel is depressed. Indication that the printer is in the "manual" mode is provided by illumination of the STOP indicator at the printer control panel. The printer may accept an SIO instruction from the controlling system but is incapable of performing the operation as long as this mode prevails.

Automatic. When all necessary conditions for successful printer operation are present, the printer may be placed in the "automatic" mode by depressing the START switch at the printer control panel. The START indicator lights when the printer enters the "automatic" mode. In the "automatic" mode the printer is capable of accepting and performing any valid operation ordered by the controlling system. If any condition should arise that would prevent the printer from functioning properly or if the operator should activate the RESET or STOP switch at the printer, it will leave the "automatic" mode and enter the "manual" mode.

TRANSITIONS BETWEEN STATES

The conditions that cause the printer to change from one state to another are summarized in Table 3. The logical switching sequence between various machine states is illustrated in Appendix A.

DATA TRANSFER

A print operation is initiated by the controlling system with a START INPUT/OUTPUT (SIO) instruction if the following conditions are satisfied:

1. input/output address recognition occurs
2. the printer is in the "ready-automatic" state
3. there is no interrupt pending

When the printer is in the "automatic" mode after accepting the SIO instruction, it will request an order. The printer controller can accept three types of orders: Print, Print with Format, and Format.

After accepting a Print order, the printer controller receives a string of bytes, representing the line of characters to be printed, and stores it in the printer's character buffer. When the entire string has been received, the line is printed and the paper is automatically upspaced. Order modifiers may be

Table 3. Line Printer State Transitions

Next State / Present State	Not Operational	Ready Manual	Busy Manual	Ready Automatic	Busy Automatic
Not Operational	_____	Power on and no paper runaway condition	Not possible	Not possible	Not possible
Ready Manual	Printer power failure or power off	_____	SIO received	START switch is operated and no fault condition exists	Not possible
Busy Manual	Printer power failure or power off	Invalid order, or I/O reset signal, or HIO, or FAULT RESET switch operated	_____	Not possible	START switch is operated and no fault condition exists
Ready Automatic	Printer power failure or power off	STOP or FAULT RESET switch operated, or operator intervention required	Not possible	_____	SIO received
Busy Automatic	Printer power failure or power off	FAULT RESET switch operated, or execution completed and no order pending, or operator intervention required	STOP switch operated and execution completed but order pending, or operator intervention required	Operation completed and manual intervention required, or HIO, or I/O reset signal, or invalid order	_____

combined with the basic Print order to specify additional operations such as generating interrupt signals. Byte counts of less than or greater than 132 bytes for printing cause the printer to generate an "incorrect length" signal. The printer does not generate a "channel end" signal after receiving 132 bytes; instead, it accepts bytes until the count is met.

Operations for a Print with Format order are the same as those for the Print order except that the first data byte received by the printer controller must be a format control character (see "Format" under "Print Orders" in Chapter 3). If a full line is to be printed, a byte count of 133 must be

specified to include the format control byte and the 132 printable characters. Following the receipt of a valid format byte, paper motion will start and data transfer will occur while paper is in motion but no printing will be done until paper movement is completed.

Following the receipt of a Format order, the printer controller will accept one byte of data that represents a format control character. The proper motion operation is performed but no printing occurs for this order.

If the printer controller receives an invalid order, it generates an "unusual end" signal.

3. PROGRAM INTERFACE

PRINT ORDERS

Print orders specify the operation (Print, Format, or Print with Format) to be performed and the interrupt signals to be generated. Bit 1 of the print order represents the modifier (see "Print Order Modifier"), and bits 5 through 7 identify the specific operation (bits 0, 2, 3, and 4 contain zeros).

In the following descriptions the letter m represents the modifier code portion of the print order.

PRINT A LINE (m1)

Prints one line of up to 132 characters and automatically upspaces paper one line after the last character is printed.

FORMAT (m3)

Positions paper as specified by the format control code contained in a single output data byte addressed by the controlling system. A byte count of 1 is mandatory in this case, since the printer is concerned with only the one byte that specifies the format code. The format control codes are listed below.

Hex Code	Character	Function
60, E0	-	Inhibit Auto Space after Print (meaningful only when used with Print with Format order)
C0	-	Space 0 lines
C1	A	Space 1 line
C2	B	Space 2 lines
C3	C	Space 3 lines
C4	D	Space 4 lines
C5	E	Space 5 lines
C6	F	Space 6 lines
C7	G	Space 7 lines
C8	H	Space 8 lines
C9	I	Space 9 lines

Hex. Code	Character	Function
CA		Space 10 lines
CB		Space 11 lines
CC		Space 12 lines
CD		Space 13 lines
CE		Space 14 lines
CF		Space 15 lines
F0	0	Skip to Channel 0 (bottom of page) [†]
F1	1	Skip to Channel 1 (top of page)
F2	2	Skip to Channel 2
F3	3	Skip to Channel 3
F4	4	Skip to Channel 4
F5	5	Skip to Channel 5
F6	6	Skip to Channel 6
F7	7	Skip to Channel 7

If the data byte does not contain a legal format code, no action occurs (i. e., the printer performs no operation).

PRINT WITH FORMAT (m5)

Positions paper as specified by the format control code contained in the first byte of the addressed output byte string. When paper motion is finished, prints one line of up to 132 characters (132 bytes following format control byte) and automatically upspaces the paper one line after printing the last character. The format control byte is not printed; however, the byte count specified must include the format control byte and the number of printable characters (i. e., a byte count of 133 if a full line is to be printed), otherwise an "incorrect length" signal will be returned to the controlling system. Paper may be held stationary before and after printing if specified by the format control code. Format control codes were listed under "Format".

[†]See "Automatic Form Control".

PRINT ORDER MODIFIER

Print orders may specify an interrupt signal to be generated for a given print operation. This modifier is written in bit 1 of the print order. The order code for Print Format, or Print with Format combined with the desired modifier bit comprise the complete order for the print operation.

In the following descriptions the letter p represents the operation code portion of the print order.

INTERRUPT AT DATA TRANSMISSION COMPLETED (4p)

The line printer will generate a "DTC" signal immediately upon ascertaining that the last character has been received for a given Print order or Format order. This signal issues an interrupt call to the controlling system if specified by a 1 bit in the second most significant bit position of the print order (Print = 41, Format = 43, Print with Format = 45).

Note: Use of this interrupt is intended primarily for Sigma 2 operation. Since its function parallels that of "Interrupt on Zero Byte Count (IZC)", it is not recommended for Sigma 5 or Sigma 7 usage.

FORMATTING

The line printer provides both automatic and ordered formatting. In both cases the proper format for a printer page must be defined by an 8-channel paper tape loop at the vertical format unit (VFU) station. Paper tape loop channels 0 and 1 are preassigned by the printer as follows:

Channel	Function
0	bottom of page
1	top of page

AUTOMATIC FORM CONTROL

Two format features of the line printers are automatic functions. One feature provides an upspace of one line following each completed print operation. This feature may be suppressed only by using a Print with Format order in conjunction with the Inhibit Auto Space after Print format control byte.

The second automatic form control feature provides a page overflow slew operation from the bottom of the current page to the top of the next page. Upon sensing a punch in channel 0 (which defines the bottom of the page) during a spacing operation, the printer immediately cancels any spacing operation in process (automatic or ordered) and slews (ejects) paper until a punch is sensed in channel 1, which defines the top of the page. A punch in channel 0 is ignored if encountered during a "skip to channel" operation, specifying a

different channel from channel 0. Since the overflow to the new page occurs before printing, channel 0 must be punched in the paper tape loop one line below the last printing line.

Automatic page overflow can be inhibited by issuing a Skip to Channel 0 format code before channel 0 is sensed. This will cause the printer to slew paper until channel 0 is sensed at the bottom of the page; printing (such as several lines of totals) can then resume at that point. After these lines are printed, overflow to a new page can be forced with a Skip to Channel n format code.

ORDERED FORM CONTROL

Additional format control is provided through device control orders issued by the controlling system. The exact paper movement to take place is specified by a single data byte transmitted to the printer following a Format or Print with Format order. The data bytes, or format control codes, that may be used were listed previously under "Format" print order. Generally, ordered formatting takes place immediately upon receipt by the printer of the format control code. If a previously ordered print or format operation is in process, the printer will delay execution of the current format order until the operation in process is completed. Byte counts other than 1 for Format orders cause the printer to issue "incorrect length" and "unusual end" signals to the controlling system. Format order modifiers are provided to specify an interrupt when the required paper movement has been initiated.

KEY EVENTS

The key events that occur during a print operation are described in the following paragraphs. No chronological order should be assumed from the order of presentation.

START INPUT/OUTPUT

A line printer operation is initiated with the execution of a START INPUT/OUTPUT instruction by the controlling system. If I/O address recognition exists and the printer is in the "ready" condition with no interrupt pending, the controlling system sets its "I/O address recognition" and "SIO accepted" indicators; meanwhile, the printer advances from the "ready" to the "busy" condition. In the "automatic" mode the unit requests an order byte from the controlling system and waits for the order byte to arrive.

UNUSUAL END CONDITIONS

The detection of any of the following conditions causes a "busy" line printer to return a device "unusual end" indication to the controlling system:

1. invalid order code
2. IOP halt during data transmission[†].
3. more than one byte transmitted to the printer with a Format order

[†]Not applicable to Sigma 2

4. absence (or failure) of ac or dc power
5. operator pressing the FAULT/RESET switch
6. paper runaway
7. parity error detection during data transmission to printer
8. printer buffer parity error

Occurrence of an "unusual end" condition cancels command chaining (if applicable).

CHANNEL END CONDITIONS

The line printer signals "channel end" to the controlling system for every order. During normal operation this occurs after printing and paper movement (if any) is completed; in case of an "unusual end" condition, the "channel end" may occur early.

FAULT CONDITIONS

A fault condition, generally, is any condition that causes a peripheral device to switch to the "not operational" state. For the line printer, either of the following conditions might occur during a printing operation:

1. paper runaway
2. absence (or failure) of ac or dc power
3. buffer parity error

ERROR CONDITIONS

Detection of an abnormal condition during a print or format operation may be reported from either or both the I/O controlling system and the line printer controller. The reaction of the printer subsystem to each condition varies. Upon detecting an internal error, the printer generally will try to complete any operation in process and, thereafter, refuse to accept any further order until the error condition is corrected. The following are some of the error conditions that might occur.

TRANSMISSION DATA ERROR

The printer is capable of detecting a parity error in data transmitted by the controlling system. The transmission error is reported to the controlling system by the printer as "unusual end". The print buffer is cleared and all printing and paper motion is cancelled. The programmer may repeat the operation from the beginning, since no printing or paper motion will have occurred.

INCORRECT MESSAGE LENGTH – PRINTING

When fewer than or more than 132 bytes of data are transmitted to the printer for printing, an "incorrect length" signal is returned to the controlling system at "channel end". If fewer than 132 bytes were transmitted, the printer sets the remaining positions to print blanks. If more than 132 bytes are transmitted, the first 132 bytes are printed and the remaining bytes are ignored. Printing will not begin until the last byte, as determined by the controlling system byte count, has been transmitted.

INCORRECT MESSAGE LENGTH—PRINTING WITH FORMAT

If fewer than or more than 133 bytes of data are transmitted to the printer following a Print with Format order, an "incorrect length" signal is returned to the controlling system at channel end. The printer accepts the first byte as a format control code and accepts all data bytes thereafter as discussed above. The reaction to this condition is the same as for printing without format.

INCORRECT MESSAGE LENGTH – FORMAT

More than one byte was transmitted to the printer. Since the printer acts on only the first byte for formatting, all additional bytes are rejected. The printer performs the format operation specified by the first byte, and then, when paper motion is completed, signals "channel end", "unusual end" and incorrect length to the controlling system. If the control code contained in the original byte was intended, the operation need not be repeated.

INVALID ORDER FROM CONTROLLING SYSTEM

If an invalid (undefined) order is received, the printer responds by immediately issuing "channel end" and "unusual end" to the controlling system. No operation takes place. The programmer must correct the order and restart the printer operation.

PRINTER BUFFER PARITY ERROR

The printer detected a parity error in its internal character buffer. All characters of the message positioned previously on the print drum were printed. The characters in printing position at the time the parity error was detected, and all subsequent characters, are skipped (i.e., set to blanks). Paper is not upspaced. "Unusual end" and "channel end" are signalled. The program may then attempt to reprint the affected line. However, care must be taken to avoid damage to the print platen by repeatedly superimposing the partial line of print. The fault indicator may be reset by depressing the FAULT/RESET switch on the printer control panel.

PAPER RUNAWAY

This condition may occur because a channel on the format control paper tape loop does not contain a punch (channel 0 through 7) or because of logic failure in the vertical format control circuits. The printer will automatically terminate any paper slew operation in excess of three seconds and may generate an "unusual end" signal depending on the portion of printer cycle at which the runaway occurred. The printer assumes a "manual" mode until properly reset at the printer control panel. The cause of the paper runaway should be corrected before resetting the printer.

PRINTER POWER FAILURE

In the event of an internal power failure, the printer will try to complete any operation in process prior to complete shutdown. The printer is generally capable of printing a complete line before losing all power. Correct completion of format operations depends on the distance paper is to be moved.

Paper Low

This condition is caused by the closing of the form detection switch at the print station. The printer is placed in a "manual" mode by the condition. Manual intervention must be taken to replenish the paper supply and to return the printer to the "automatic" mode.

LINE PRINTER STATUS RESPONSE

The line printer subsystem is capable of returning various status flags in response to computer-executed I/O instructions. Detailed explanations of the input/output instructions that request status of the line printer are contained in the reference manuals for the Sigma computers. The following paragraphs explain the significance of each status flag returned to the controlling system by the line printer.

The various control switches (START, FAULT/RESET, etc.), mentioned in the following discussion, are described in Chapter 4, "Operations".

I/O INSTRUCTION STATUS BITS

The execution of an I/O instruction by the controlling system provides 2 bits of immediate information pertaining to the general status of the addressed I/O device and its controller. This information is retained by the controlling system in a form that allows for conditional branching based on the response to the I/O instruction. Table 4 lists the I/O instructions, the possible status bit settings provided by each I/O instruction, and the significance of each setting.

DEVICE STATUS BYTE

The following eight bits of information are made available to the computer in response to the execution of an I/O instruction.

STATUS RESPONSE FOR SIO, TIO, AND HIO

Bit 0: Device Interrupt Pending. If this bit is 1, an interrupt call is pending (issued but not yet acknowledged) as the result of a condition specified by a modified device order (data transmission completed) or specified by the controlling system ("channel end", "unusual end", or "zero byte count"). The printer will accept data but will not accept further SIO instructions until the condition is cleared. The condition can be cleared by an AIO or HIO instruction.

Bits 1-2: Printer Operational Status. A combination of these two flags reflects the line printer's current operating status:

<u>Flags</u>	<u>Status</u>
00	Printer Ready – the printer is capable of accepting an SIO instruction.
01	Printer Not Operational – the printer is not capable of accepting an SIO instruction due to a local abnormal condition. This condition exists when the line printer has not been turned on.

Flags Status

10	Device Unavailable – this condition status is not applicable to the line printer.
11	Printer Busy – the printer is currently engaged in executing a previous order and is unable to accept a new SIO instruction.

Bit 3: Mode – Automatic or Manual. If this bit is 0, the line printer is in the "manual" mode; therefore, manual intervention is required to make it operational. Bit 3 will be 1 if the line printer is in the "automatic" mode and, thus, available to the controlling system for operation.

Bit 4: Device Unusual End. This bit is set to 1 if the previously ordered print or format operation was terminated due to an abnormal condition in the controlling system or line printer. A TEST DEVICE (TDV) instruction should be issued to ascertain the exact "unusual end" condition.

Bits 5-6: Printer Controller Operational Status. These condition states are identical to bits 1 and 2.

Bit 7: Unassigned. This status bit is currently unassigned.

STATUS RESPONSE FOR TDV

Bit 0: Not Used.

Bit 1: Print Fault. If the printer detected a parity error in data from its own internal character buffer, this bit is set to 1.

Bit 2: Paper Low. This bit is 1 when the form detection switch at the print station has closed indicating the absence of paper.

Bit 3: Top of Page. If this bit is 1, a punch was sensed in channel 1 of the vertical format control tape indicating paper is positioned at the first line of the page.

Bit 4: Paper Moving. This bit is 1 when an ordered or automatic format operation is in process and paper is currently in motion.

Bit 5: Paper Runaway. Bit 5 is set to 1 to designate that the previous format operation failed to terminate within 3 seconds due to an internal circuit failure or the absence of a punch in the designated channel of the vertical format tape. Paper movement is terminated by the printer, and the "fault" condition is assumed. This condition must be cleared by depressing the RESET button on the printer control panel. A skip to a nonexistent channel (8-F) will not cause paper runaway but will be treated as a "no-action" operation.

Bits 6-7: Not Used.

STATUS RESPONSE FOR AIO

Bit 0: Not Used.

Table 4. Line Printer I/O Instruction Execution Response

Instruc- tion	Code				IOP Type			Address/ Interrupt Recogni- tion	Opera- tion Accepted	Status Returned To CPU Registers	Significance
	CC-1 ($\Sigma 5/7$)	Overflow ($\Sigma 2$)	CC-2 ($\Sigma 5/7$)	Carry ($\Sigma 2$)	Multi- plexor	Inte- gral	Selector				
SIO	0		0		Yes	Yes	Yes	Yes	Yes	Yes	Device was "ready", now "busy".
	0		1		Yes	Yes	Yes	Yes	No	Yes	Device was "not ready".
	1		0		No	No	Yes	Yes	No	No	Selector IOP was "busy"(not applicable to Sigma 2).
	1		1		Yes	Yes	Yes	No	No	No	I/O address not recognized.
HIO	0		0		Yes	Yes	Yes	Yes	Yes	Yes	Device (and selector IOP) was "not busy".
	0		1		Yes	Yes	Yes	Yes	Yes	Yes	Device (and/or selector IOP) was "busy".
	1		0		No	No	No	No	No	No	Invalid code.
	1		1		Yes	Yes	Yes	No	No	No	I/O address not recognized.
TIO	0		0		Yes	Yes	Yes	Yes	Yes	Yes	Device is "ready".
	0		1		Yes	Yes	Yes	Yes	Yes	Yes	Device is "not ready".
	1		0		No	No	Yes	Yes	No	No	Selector IOP is "busy" (not applicable to Sigma 2).
	1		1		Yes	Yes	Yes	No	No	No	I/O address not recognized.
TDV	0		0		Yes	Yes	Yes	Yes	Yes	Yes	I/O address recognized; no "fault" condition exists at printer. (Normal response).
	0		1		No	No	No	No	No	No	"Fault" condition (i. e., paper low, paper runaway, etc.) exists at the printer.
	1		0		No	No	Yes	Yes	No	No	Selector IOP is "busy" (not applicable to Sigma 2).
	1		1		Yes	Yes	Yes	No	No	No	I/O address not recognized.
AIO	0		0		Yes	Yes	Yes	Yes	Yes	Yes	Normal interrupt recognition.
	0		1		Yes	Yes	Yes	Yes	Yes	Yes	Abnormal interrupt recognition.
	1		0		No	No	No	No	No	No	Invalid code.
	1		1		Yes	Yes	Yes	No	No	No	No interrupt recognition.

Bit 1: Data Transmission Completed. A 1 in this bit position indicates that the interrupt occurred as the result of receiving the last byte of data after an order specifying such an interrupt.

Bits 2-7: Not Used.

OPERATIONAL STATUS BYTE

In addition to the information contained in the device status byte, the following indicators are made available to the controlling system in the operational status byte transmitted at "channel end".

INCORRECT LENGTH

If this flag is a 1, an incorrect length condition has occurred since the previous output order was received by the line printer (also see "Error Conditions").

TRANSMISSION DATA ERROR

If this flag is a 1, the printer has detected a parity error in data transmitted by the controlling system (also see "Error Conditions").

CHANNEL END

If this flag is a 1, the printer has released the channel for any of the reasons listed under "Channel End Conditions".

PROGRAMMING CONSIDERATIONS

The following diagram illustrates the sequential relationship of the key events that occur during a line printer operation.

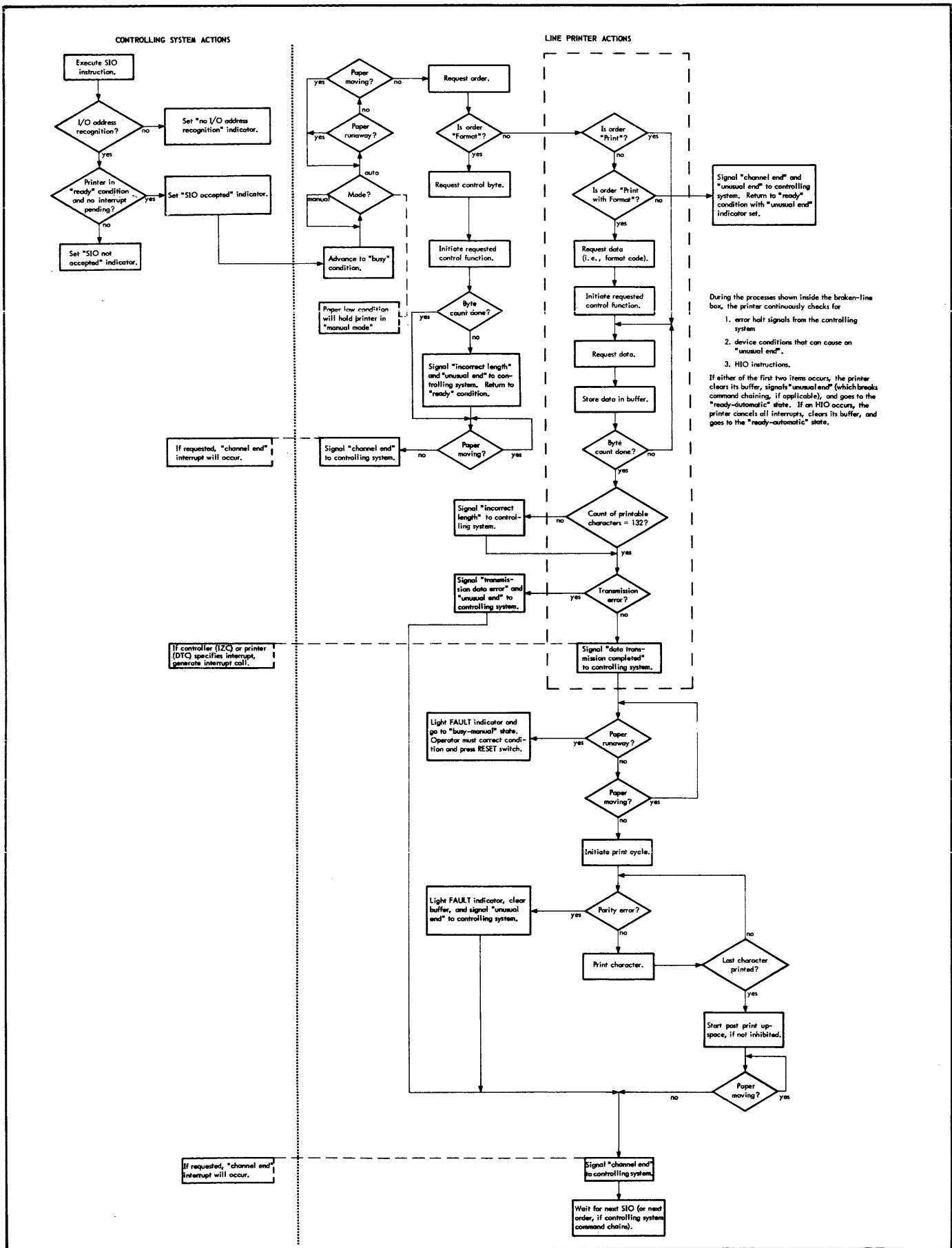

Figure 1. Controlling System/Line Printer Actions

4. OPERATIONS

OPERATOR CONTROLS

The controls available for the electronic operation of the 7440/7445 Line Printers are mounted on a panel on the upper right front corner of the cabinet. This panel is shown in Figure 2.

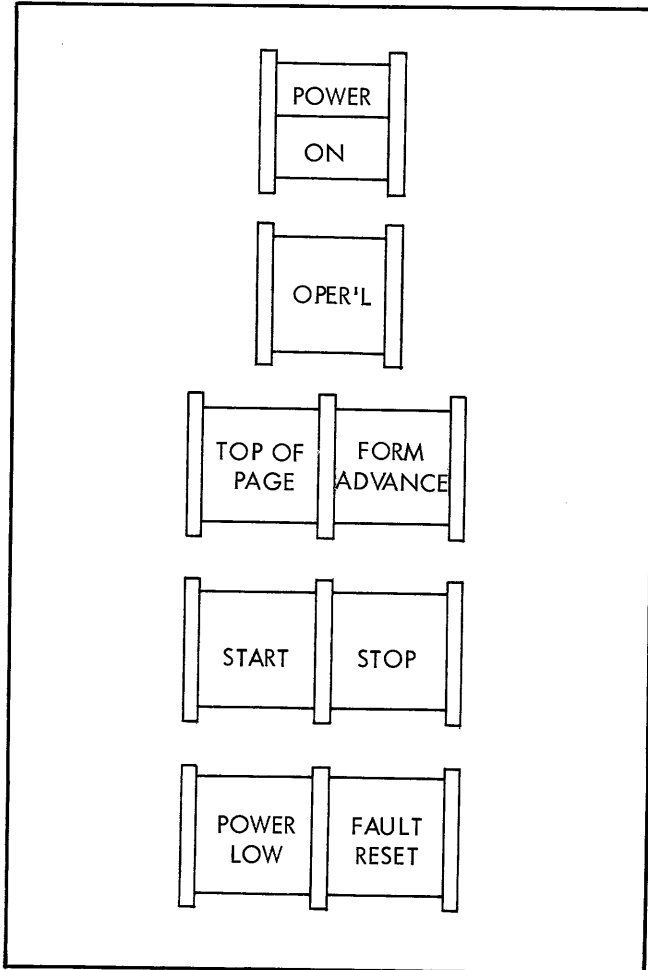

Figure 2. Control Panel

POWER ON

Alternate-action indicator switch. The operator depresses this switch to apply basic power to the unit. The top half of the switch lights immediately, indicating that dc power is on. After a suitable delay, while the unit stabilizes, the bottom half of the switch automatically lights.

OPERATIONAL

The operational (OPER'L) indicator is illuminated when all necessary power is present.

TOP OF PAGE

Momentary-action indicator switch. If the printer is in "manual" mode, depressing this switch causes the printer to

upspace until a hole is sensed in channel 1 (top of page) of the vertical format control tape. The indicator lights whenever the page is situated at top of page. If there is no vertical format control tape in the VFU, each depression of the TOP OF PAGE switch causes a single upspace operation, and the indicator is illuminated after each operation. If the vertical format tape sensing assembly is left in the open position, depressing the TOP OF PAGE switch causes continuous paper feed operation for a maximum of three seconds.

FORM ADVANCE

Momentary-action indicator switch. Depressing this switch causes the printer to upspace one line. The indicator glows continuously whenever system power is on.

START

Momentary-action indicator switch. If the printer is operational and paper is present, depressing this switch causes the printer to go to the "automatic" mode. The indicator remains lighted while the printer is in the "automatic" mode. The STOP indicator is turned off.

The TOP OF PAGE and FORM ADVANCE switches are inoperative as long as the printer is in the "automatic" mode; however, the TOP OF PAGE indicator will still light whenever channel 1 of the vertical format control tape is sensed.

The "automatic" mode can be reset by a power-off/power-on sequence, by depressing the STOP switch, by a PAPER LOW condition, or by depressing the RESET switch.

STOP

Momentary-action indicator switch. Depressing this switch causes the printer to go to the "manual" mode. Any operation currently in progress continues until completion. The STOP indicator remains lighted while the printer is in "manual" mode, and the START indicator is turned off.

PAPER LOW

This indicator lights when the paper supply is inadequate. When this condition occurs, the printer goes to the "manual" mode.

FAULT/RESET

Momentary-action indicator switch. The indicator lights whenever a fault is detected in the printer system. Depressing this switch clears all printer conditions and causes the unit to go to the "manual" mode and "ready" condition. An "unusual end" will occur if the printer is communicating with the controlling system when the switch is activated.

OPERATING PROCEDURES

The main procedures required for operation of the 7440 and 7445 Line Printers are given in the following paragraphs. The paragraphs on ribbon and paper loading include characteristics for reordering.

PAPER LOADING

Although a supply of paper[†] is provided with the printer, the paper must be properly loaded before operating the printer. The following procedure is used to load paper into the line printer. Refer to Figures 3 and 4.

- a. Relax paper tension mechanism by lowering form tension lever to its lowest position.
- b. Loosen input tractor locks and laterally position tractors to receive paper.

[†]The paper supplied is edge-punched and continuous, with perforations between individual forms. The paper is fan-folded on the perforations. Any variation in width and length of forms is possible within the limits of the overall size specifications. Either pre-perforated or special paper can be used as long as the paper meets the specifications in Table 5.

- c. Position output tractors relative to input tractors using columnar scales.
- d. Thread paper between typeline shield and paper table.
- e. Mount paper on left input tractor sprockets, close tractor guide plate, and tighten left input tractor lock.
- f. Adjust right input tractor laterally until paper sprocket holes are centered over the tractor sprockets.
- g. Mount paper on right input tractor sprockets, close tractor guide plate, and tighten right tractor lock.
- h. Repeat steps e through g for output tractors.

Note: Lateral adjustment of both input or output tractors can be made by the use of the fine lateral adjustment controls. These allow simultaneous lateral adjustment of both left and right tractors.

- i. Increase paper tension by raising form tension lever until the holes in the paper are slightly deformed.

When new supplies of paper are required, refer to Table 5 for required characteristics.

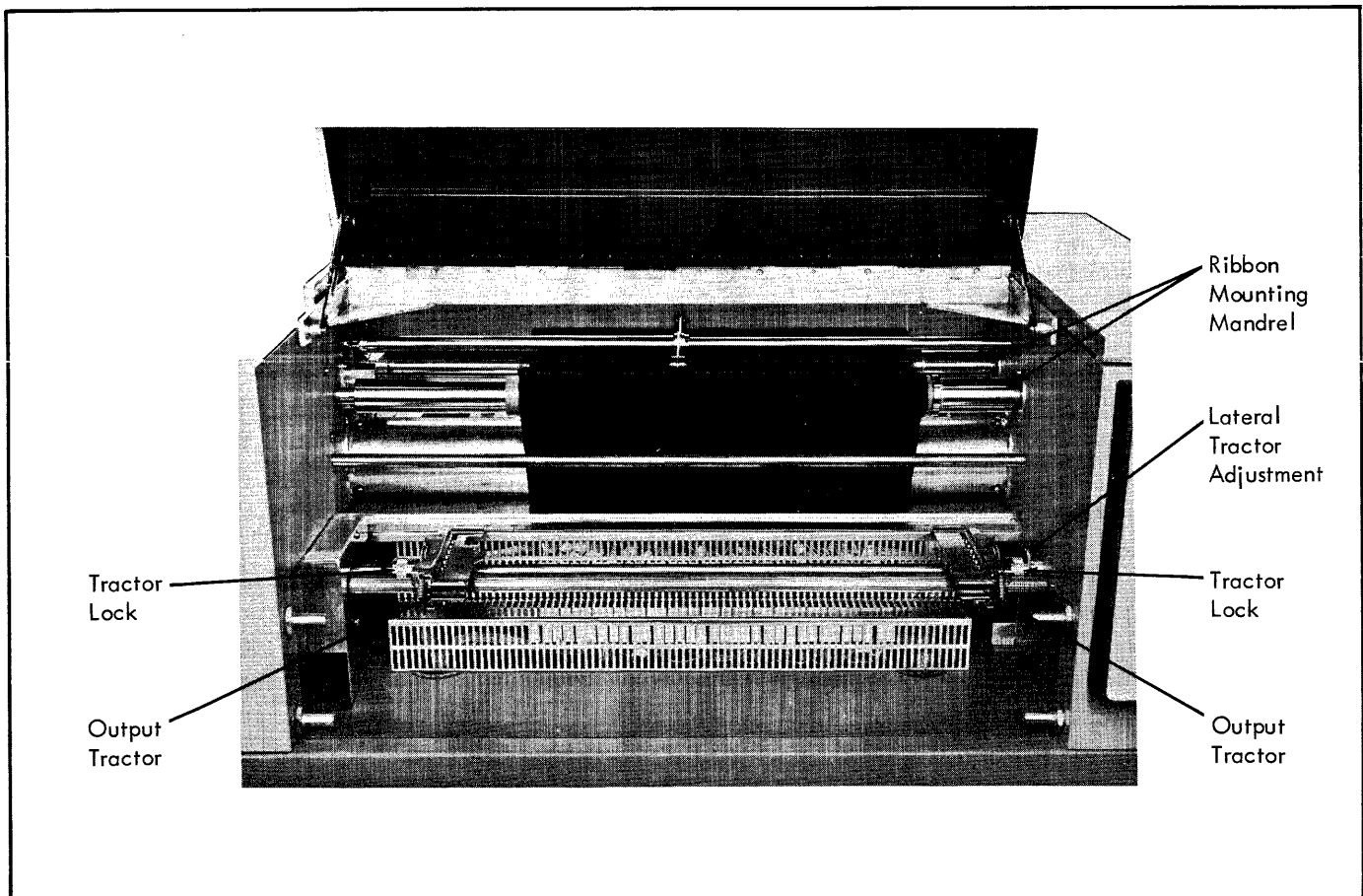

Figure 3. Printer Mechanism, Front View

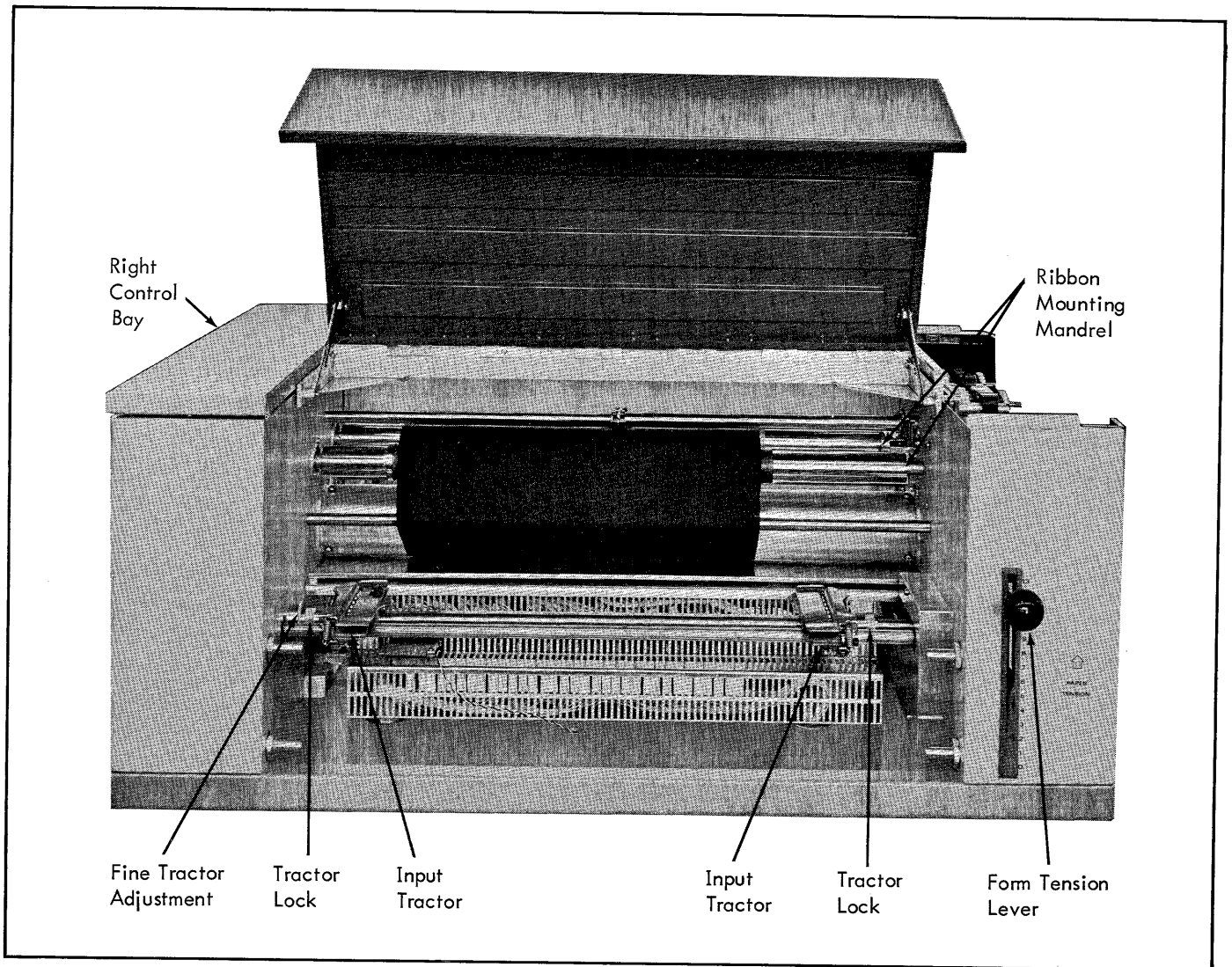

Figure 4. Printer Mechanism, Rear View

Table 5. Paper Characteristics

Characteristics	Specification
Form Width	4 in. min., 20 in. max.
Form Length	22 in. max. (with supplied equipment)
Edge Punching	Standard edge-punched (1/2-inch centers)
Number of copies	
Up to 6 parts	12-lb bond with single-shot carbon
Tabulating card	0.007 in. plus second record sheet
Single copy	Min. weight: 15-lb bond
Standard paper	20-lb, single part, 14-7/8 in. by 11 in. fanfold paper

RIBBON LOADING

The following procedure is used to load a new ribbon into the printer. Refer to Figures 3 and 4 for views of the ribbon from front and rear.

Note: Before starting the ribbon loading procedure, note the ribbon's path from the mandrels and around the guide bars is not symmetrical, and incorrect replacement of the ribbon can result in loss of print-out. Refer to Figure 5 for correct positioning.

- a. Note mandrel that has most ribbon on it (called "supply mandrel"), engage ribbon crank with the end of this mandrel, and rotate until the paper ribbon leader on the other mandrel (called "takeup mandrel") is exposed. Remove tape that holds leader to fiber sleeve and finish taking up remaining ribbon onto supply mandrel. Figure 6 shows the right control bay, which houses the ribbon crank and the ends of the mandrels.
- b. Remove supply mandrel from spring loaded mounting.

- c. Remove key from slot in mandrel, slide ribbon off, and discard.
- d. Slide new ribbon onto mandrel to unwind as shown in Figure 5 and seat ribbon firmly against the collar.
- e. Replace key in slot of mandrel and rotate ribbon so that key also engages slot in fiber sleeve on which ribbon is wound.
- f. Replace mandrel in spring loaded mounting.
- g. Thread ribbon as shown in Figure 5 so that it goes around front ribbon guide bar, between typeline shield and paper table, and over rear ribbon guide bar.
- h. Center fiber sleeve that has remained on takeup mandrel and assure that the leader slot is aligned with the slot in the sleeve.
- i. Secure the ribbon to the sleeve by taping.
- j. Rotate takeup mandrel a few turns with ribbon crank and assure that ribbon is feeding smoothly.

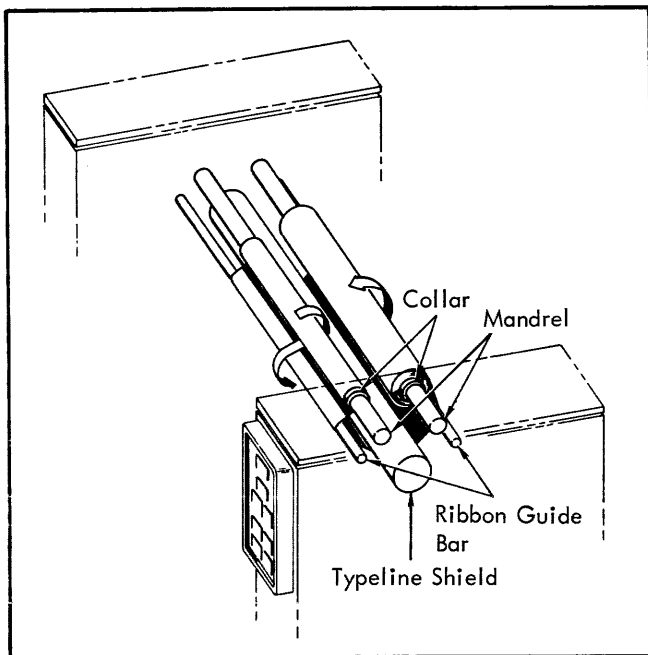

Figure 5. Ribbon Mounting

When the ribbon supplied with the printer becomes unusable, it must be replaced with one having the specifications listed in Table 5.

Table 6. Ribbon Characteristics

Characteristics	Specifications
Width	14.5 inches
Length	36 yards
Material	Nylon, all purpose
Ink Content	19%-23% by weight
Ink Color	Blank Record

TURN-ON/TURN-OFF PROCEDURES

The turn-on/turn-off procedures are performed with the controls shown in Figure 1. The printer cannot function without dc power being supplied from the computer. When computer power is on, the POWER ON switch controls the ac power to the drive motors and the power supply in the printer, and the POWER indicator will light. A time delay of approximately 20 seconds allows the motors to reach operating speed and the power supply to stabilize. At the end of this time, the ON part of the POWER ON switch is illuminated.

The POWER ON switch is operated to remove ac power from the drive motors and from the printer power supply.

Note: If a power failure occurs at any time after the start of transmission of the line to the printer, the printer is normally capable of printing the line before power drops to an unusable level, (see "Printer Power Failure" in Chapter 3).

PHASING CONTROL

The following procedure is required only when changing types of paper or changing the number of copies being printed. Refer to Figure 6 for location of the control.

- a. Feed in known data.
- b. Observe printout to see if data is printed correctly.
- c. If printout is garbled or partial characters are being printed (ghosting), adjust phasing control located above the code disc to obtain good printout.
- d. Maintain a record of phasing control setting for each type of form used.

VERTICAL PRINT LINE ADJUSTMENT

If characters are not aligned with lines on the paper, perform the following adjustment. Refer to Figure 6 for location of the control.

- a. Feed in data.
- b. Observe printout.
- c. Adjust vertical print line adjustment control for proper print position.

INTENSITY CONTROL ADJUSTMENT

Perform the following adjustment when the print intensity of the output is unacceptable. The intensity control settings will vary with the number of forms and the age of the ribbon. Refer to Figure 6 for the location of the control.

- a. Feed in known data.
- b. Observe printout.
- c. If printout is too light, increase intensity control. If printout is too dark, decrease intensity control.
- d. Maintain a record of the intensity control settings for each type of form used.

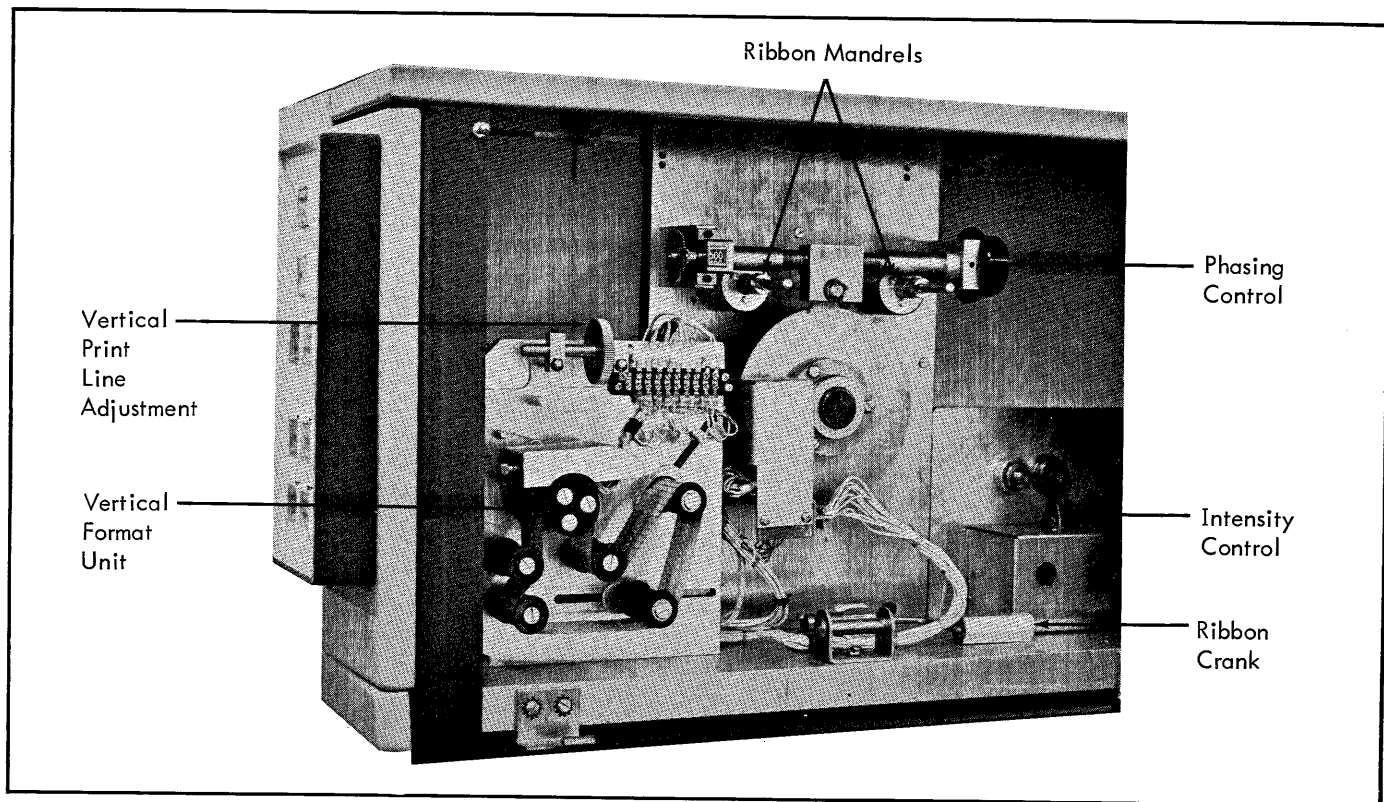

Figure 6. Right Control Bay

VFU TAPE LOADING

The following procedure is to be used for loading a standard prepunched and precut vertical format control tape loop.

- a. Move tape spools to allow tape to be mounted (see Figure 6).
- b. Raise sensing head.
- c. Place tape loop onto spools with the edge numbers increasing in the clockwise direction

Note: Since the tapes are symmetrical, care must be taken to prevent loading the tape backwards.

- d. Take up tape slack by adjusting the spools until the tape is seated on spools. Do not overtighten because excessive tension on the tapes causes excessive wear.
- e. Lower sensing head.

VERTICAL FORMAT TAPE PREPARATION

The vertical format unit drive drum and tapes are made so that each line on the tape corresponds to a printed line on the paper. For every line the paper is advanced, the tape also is advanced a line. The vertical format unit pickup generates a signal each time a punch is sensed in the tape. These signals are sensed to determine the position of the form.

The minimum tape length is 10 inches. This is the shortest tape that the vertical format unit can handle and is equivalent to a tape of 60 lines.

VERTICAL FORMAT TAPE PUNCH

The specific configuration of holes on the tape is determined by the programming application. The punch shown in Figure 7 is used to punch holes into a vertical format tape. As the tape is fed through the punch, the column that is 10 spaces away from the one being punched is lined up with the scribe mark. The alignment of the tape in the punch is shown in Figure 8.

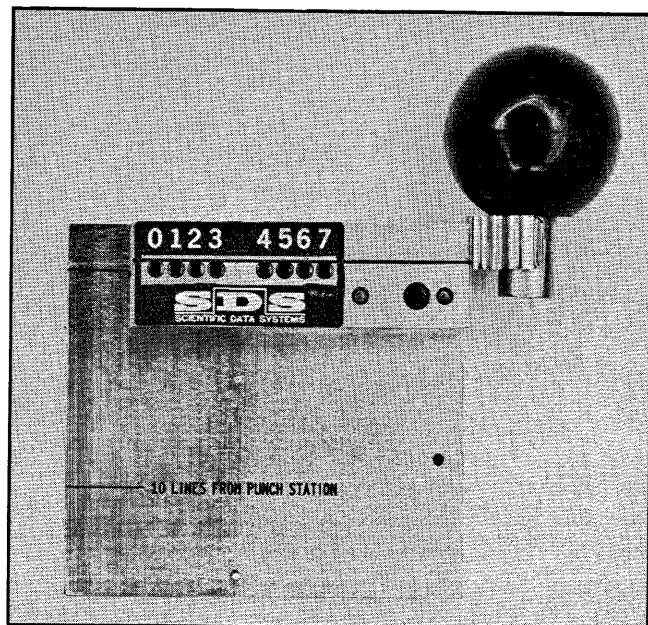

Figure 7. VFU Tape Punch

PREPARING STANDARD TAPES

The items required to prepare a vertical format tape are

SDS Part Number	Item
108470-002	Vertical format tape (8-channel)
126877-002	Vertical format tape punch (8-channel), shown in Figure 7.
117201	Format tape cement

To prepare a standard vertical format tape, punch holes at each channel and line number intersection point specified in Table 7.

Table 7. Specification for Standard Tapes

Function	Tape Channel	Punch in line number	
		124804-001	124804-002
Bottom of page (BOP)	0	60	45 and 96
Top of page (TOP)	1	7	7 and 58
4 lines below TOP	2	11	11 and 62
8 lines below TOP	3	15	15 and 66
12 lines below TOP	4	19	19 and 70
16 lines below TOP	5	23	23 and 74
20 lines below TOP	6	27	27 and 78
2 lines above BOP	7	58	43 and 94
Trim line		66	102
Glue overlap area		65 and 66	101 and 102

After the tape is completely punched, the following procedure may be used to glue the ends of the tape together.

- Trim both ends of the tape as follows:
 - Trim end marked GLUE so that the 2-column glue area is at the very beginning of the tape.
 - Trim the other end at the column number corresponding to the last line of the form (row 66 or 102).
- Apply resin-base cement for vertical format tapes to face of glue area.
- Quickly loop tape, printed side out, and overlap ends by only two lines so that unmarked end just covers the glue area.
- Align sprocket holes by sighting down grid line lengthwise on tape.
- Apply light pressure to joint for 15 seconds and allow cement to dry for one hour at room temperature before further handling.

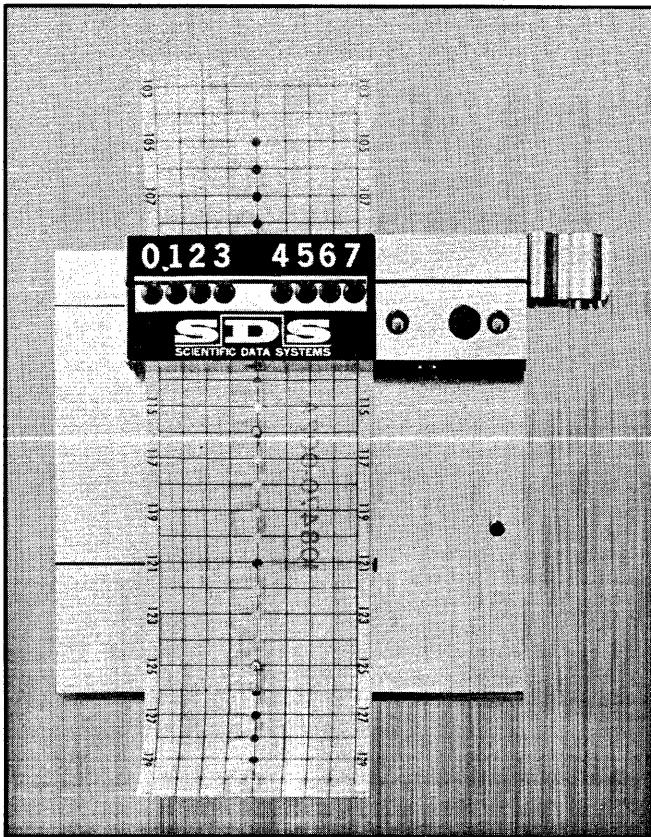

Figure 8. Tape Alignment in VFU Tape Punch

SDS STANDARD TAPES

SDS has established vertical format tapes that cover many standard printing applications. The SDS standard tapes define the top of form as the seventh line from the physical top of the perforated page and the bottom on the form as the seventh line from the physical bottom of the page.

To use the standard tape, the program issues a Format or Print with Format order that contains a hexadecimal format control code. The paper then slews until a hole is detected in the column designated by that code.

There are two standard vertical format tapes:

- 124804-001 for use with 66-line (11 inch length) forms.
- 124804-002 for use with 51-line (8-1/2 inch length) forms. This is a double length tape since a single 51-line tape is too short to be accommodated by the printer's vertical format unit.

The programmer may use an SDS standard vertical format tape or, if he prefers, he may prepare one specifically for his own application. In either case, only two channels are preempted by the printer: channel 0 is always bottom of page and channel 1 is always top of page.

A. DEVICE STATE SEQUENCES

The following figures illustrate the logical switching sequence between various machine states.

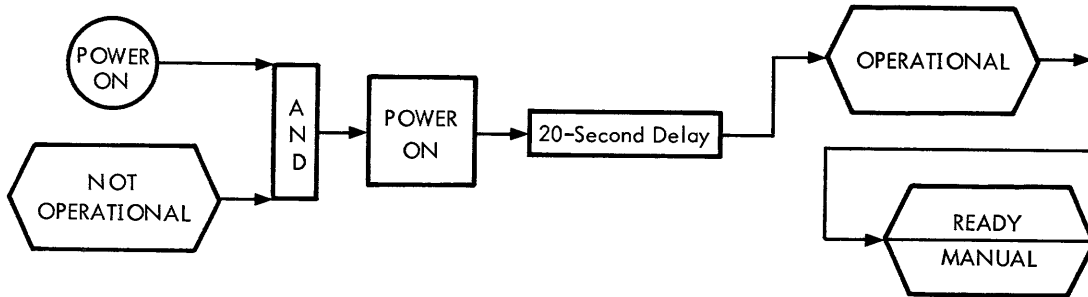
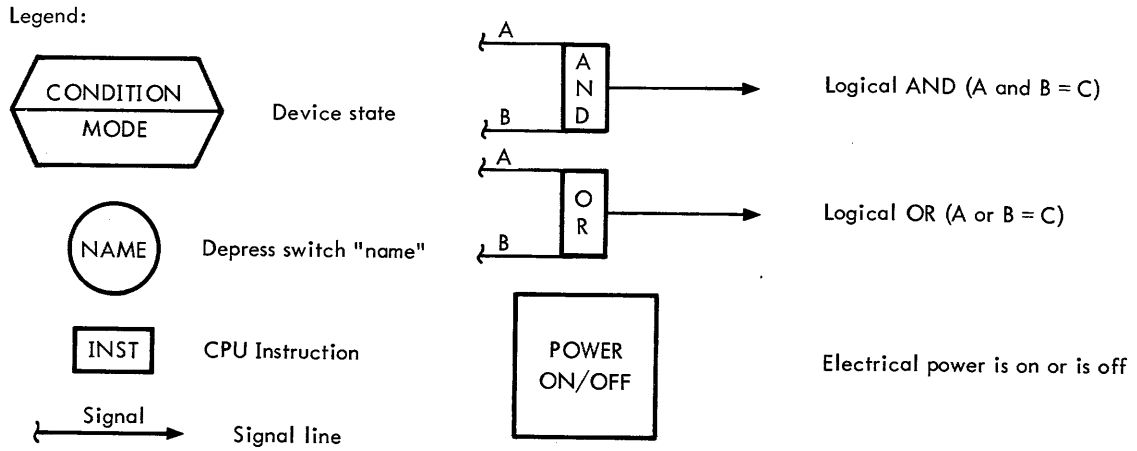

Figure 9. Device State Sequence From "Not Operational"

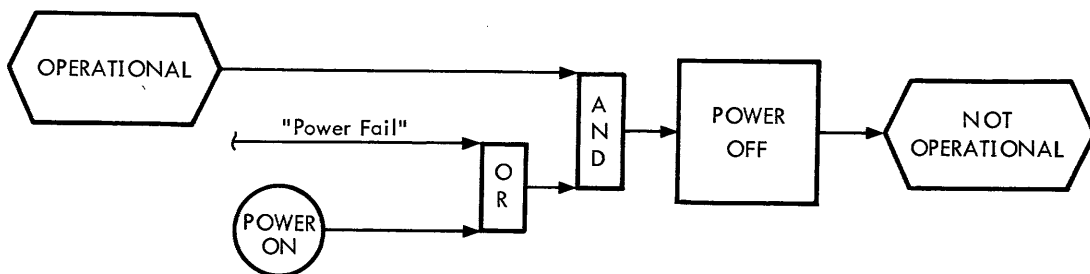

Figure 10. Device State Sequence From "Operational"

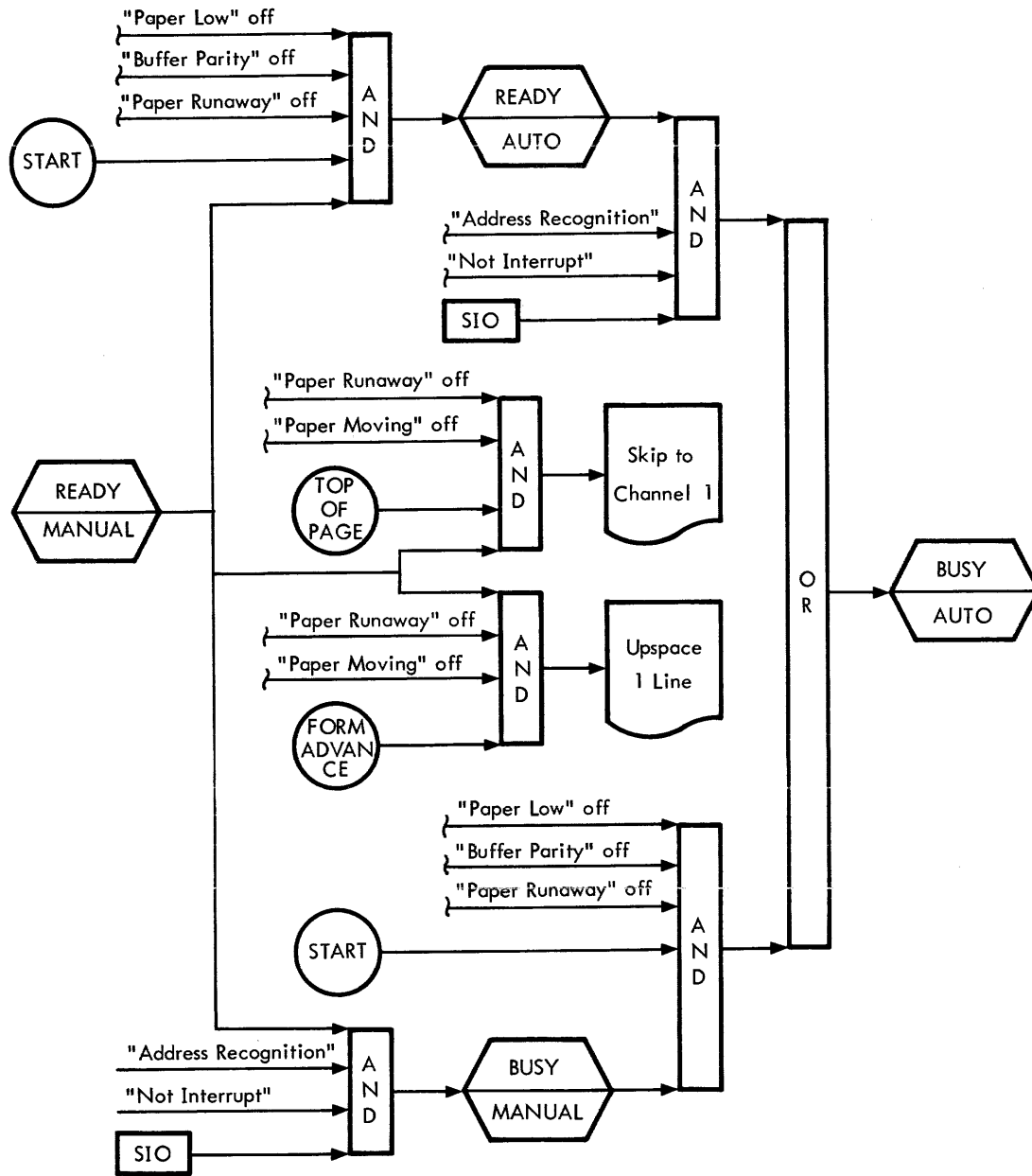

Figure 11. Device State Sequence From "Ready-Manual"

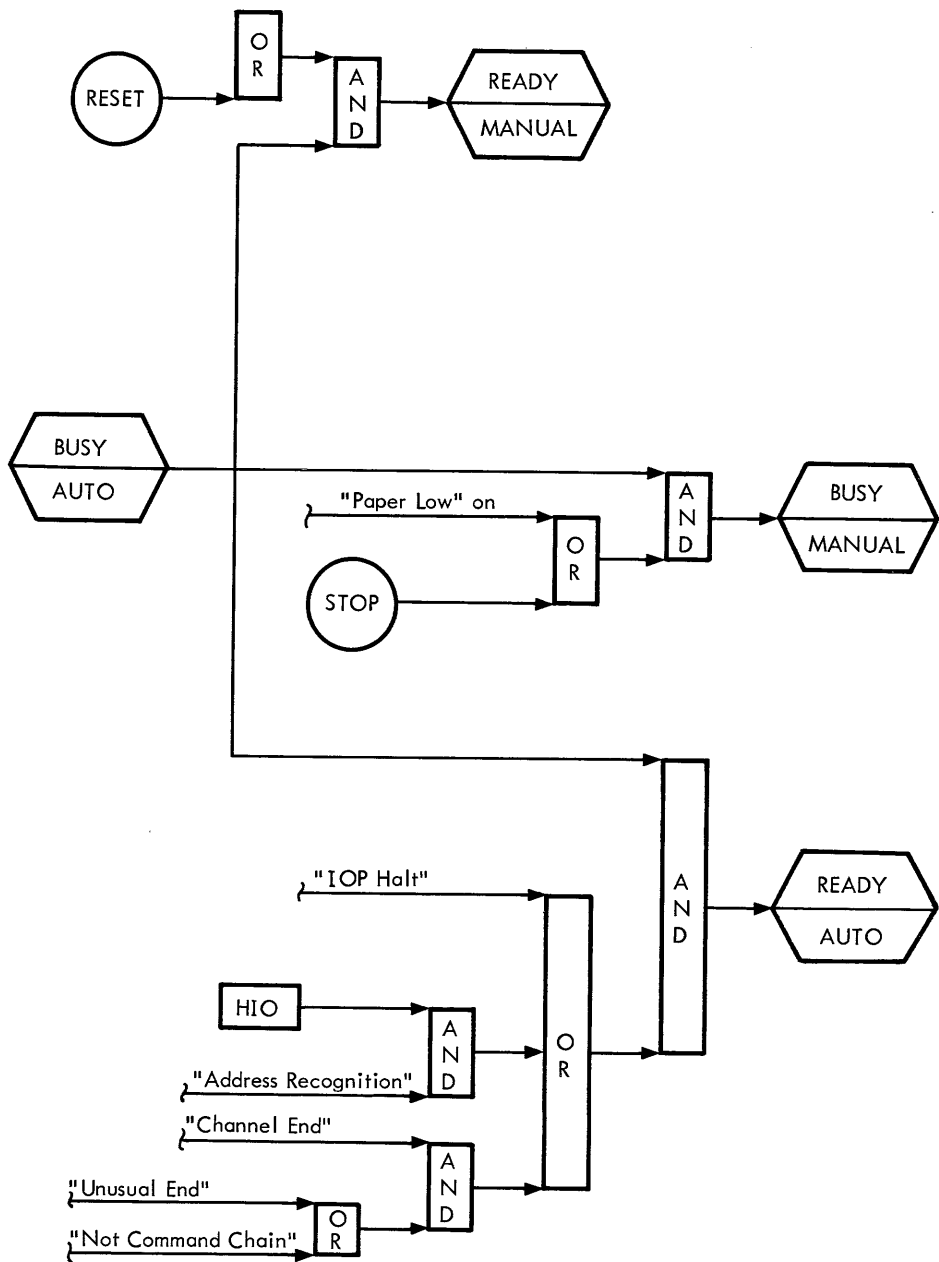

Figure 14. Device State Sequence From "Busy-Auto"

B. SIGMA 7 PROGRAM EXAMPLE

The following coding sequence illustrates a line printer program for use with an SDS Sigma 7 Computer. The program will print one line of 132 characters and upspace to the next line. This program is written as a subroutine entered by a Branch and Link instruction using register 15 (i. e., BAL,15 PRINT).

<u>Label</u>	<u>Command</u>	<u>Argument</u>	<u>Comments</u>
PRINT	NOP		Entry to print subroutine.
TESTIO	TIO,8	PRINTER	Test printer status (general register 9 will contain status response).
	STCF	TEMP	Save condition codes.
	BCR,8	\$ + 3	Check address recognition. If successful, branch to check printer mode. If unsuccessful, execute next instruction in sequence.
HALT1	WAIT	0	} Wait for manual intervention, then try again.
	BCR,0	TESTIO	
	CW,9	AUTO	Check printer mode. Bit position 3 of register 9 will contain a 1 if the printer is in "automatic" mode. This instruction will set the condition code according to the results of the comparison.
	BCS,4	\$ + 3	If CC2 is set to 1, the printer is in "automatic" mode; therefore, proceed to \$ + 3. Otherwise, execute next instruction in sequence.
HALT2	WAIT	0	The printer is in "manual" mode. Wait for operator to press START switch.
	BCR,0	TESTIO	Unconditional branch to TESTIO.
	LC	TEMP	Load condition codes that were saved previously.
	BCR,4	STARTIO	If SIO is possible (i. e., CC2 is 0), branch to STARTIO; otherwise, execute next instruction in sequence.
	BCR,0	TESTIO	Loop waiting for printer.
STARTIO	LI,0	DA(COMM1)	Load register 0 with the address of the first command doubleword.
	LW,10	IOINT1	} Set up I/O interrupt linkage.
	STW,10	X'5C'	
	LI,10	X'20'	} Arm and enable I/O interrupts.
	WD,10	X'1200'	
	SIO,8	PRINTER	Start the printer.
	BCR,4	HALT5	If SIO was successful, branch to HALT5 to wait for interrupt; otherwise, execute next instruction in sequence.
HALT4	WAIT	0	} Wait for operator intervention, then branch unconditionally to STARTIO.
	BCR,0	STARTIO	
HALT5	WAIT	0	} Wait for "channel end" interrupt to AKNIO. If no interrupt occurs, the operator should clear the halt to force subroutine to exit.
	BCR,0	EXIT	
AKNIO	AIO,8	0	Enter here on I/O interrupt and acknowledge.
	BCR,8	\$ + 2	If CC1 is zero (i. e., I/O interrupt recognition by the AIO), skip the next instruction in sequence; otherwise, execute it.
	LPSD,3	WFP	Load program status doubleword with contents of WFP. The highest priority interrupt currently in the active state is cleared, and the interrupt level is armed. Thus, the "no interrupt recognition" causes a return to HALT5 to wait for "channel end".
	BCR,4	\$ + 3	If the AIO indicated a normal interrupt, branch to determine if it is a printer interrupt; otherwise, execute the next instruction in sequence.

<u>Label</u>	<u>Command</u>	<u>Argument</u>	<u>Comments</u>
HALT6	WAIT	0	} When an abnormal condition interrupt occurs, wait for operator intervention; then try again.
	LPSD,3	RETRY	
	CI,8	PRINTER	Following normal interrupt, check for printer interrupt.
	BCR,3	\$ + 2	If it is printer, branch to \$ + 2 to continue; otherwise, execute next instruction in sequence.
	LPSD,3	WFP	Return to HALT5 to wait for "channel end".
	LPSD,3	AIOK	Interrupt was from printer. Clear interrupt and proceed to TDVIO.
TDVIO	TDV,8	PRINTER	Obtain printer device status.
	BCR,4	\$ + 3	Test for device fault (i. e., branch if no fault reported).
WAIT7	WAIT	0	If device fault, stop for operator intervention.
	BCR,0	TDVIO	Unconditional branch to TDVIO to try again.
	CW,9	PMBIT	Determine whether bit position 4 of register 9 contains a 1, indicating that printer paper is moving.
	BCS,4	TDVIO	If paper is moving, branch to TDVIO and loop, waiting for it to stop; otherwise, execute next instruction in sequence.
	CW,9	FAULTS	Double check for buffer parity error, paper runaway, or paper low.
	BCR,4	\$ + 2	If no fault condition exists, branch to \$ + 2.
HALT8	WAIT	0	If any fault condition exists, wait for operator intervention; then proceed.
EXIT	BCR,0	*15	Return to main program.
*PROGRAM CONSTANTS AND STORAGE			
PRINTER	EQU	X'102'	Printer address = IOPI, device 2.
AUTO	DATA	X'1000000'	Bit 3 = auto/manual flag.
PMBIT	DATA	X'08000000'	Bit 4 = paper moving flag.
FAULTS	DATA	X'64000000'	Bit 1 = buffer parity error; bit 2 = paper low; bit 5 = paper runaway.
TEMP	DATA	0	Temporary storage.
IOINT1	XPSD,0	CEINT	I/O interrupt at "channel end".
	BOUND	8	Set on doubleword boundary
COMM1	GEN,8,24	X'01',BA(LINE) X'1C',132	Command doubleword to print one line of 132 characters and automatically upspace to the next line: - Interrupt on "unusual end" or "channel end" - Halt on transmission error - Message to be printed begins at symbolic location LINE - Prints 132 contiguous bytes in columns 1-132.
	GEN,8,24		
CEINT	DATA	0,0	} PSDW exchange on I/O interrupt to location X'5C'.
	DATA	AKNIO,0	
WFP	DATA	HALT5,0	PSDW - Return to wait for printer "channel end".
RETRY	DATA	STARTIO,0	PSDW - Try printer operation again.
AIOK	DATA	TDVIO,0	PSDW - Proceed on printer "channel end".
LINE	RES	33	Reserve for print message.